

Dark Matter is uncatchable and its Cosmic Age can be about 100 million years, based on the special theory of relativity and the ternary space-times

Fumitaka Inuyama. Senior Power Engineer (e-mail: inusanin@yahoo.co.jp)

Permanent address: Jonan-ku Torikai 5-17-33, Fukuoka City, 814-0103, Japan

Environment Dept., Kyudensangyo Inc. (Retired) (www.kyudensangyo.co.jp)

Sayuri Taniguchi. Amateur of starry sky

Abstract Published studies have stated that the mass ratio of ordinary substances such as atoms, dark matter and dark energy are approximately five percent, twenty seven percent and sixty eight percent, respectively. However, it has not been successfully realized until today to detect and thus to prove the existence of dark matter and dark energy. There should be some fundamental problems to be addressed and the universal space-time itself must have its own hidden characteristics. It estimates here in this article the universal space-time by using the special theory of relativity i.e. the combined velocity, the increasing mass, the duration time and the chemical reaction rate. The results suggest that each of “the ternary space-times” has its own specific light velocity and that the cosmic age of dark matter uncaptured can be about 100 million years in our age of the universe 13.8 billion years.

Keywords dark matter, dark energy, ternary space-times, cosmic age

1. Introduction

The ESA (European Space Agency)’s Planck space telescope revealed in 2013 that the total mass-energy of the universe had a composition of 68.3% dark energy, 26.8% dark matter and 4.9% normal matter that makes up stars and galaxies (baryons) [1].

Baryons are ordinary substances such as atoms and elementary particles that exist in the real world.

Dark matter is the substance with the mass and influences gravitation. The existence of dark matter is perceived in terms of the rotation curve of a disk galaxy [2], visible light observations of strong effects by gravitational lens and X-ray observations of bullet clusters. There have been previous attempts to prove the existence of dark matter by using the thesis of unknown elementary particles, modified Newtonian dynamics and other methods.

The existence of dark energy is more mysterious than that of dark matter. Baryons and dark matter pull against each other in accordance with the law of universal gravitation. In contrast, dark energy has a repulsive force, i.e., it affects negative pressure and thus accelerates the expansion of the universe. The phenomena regarding the accelerated expansion of the universe are based on results that were obtained from the astronomical observations of the Hubble telescope [3]. Some scientists have associated these phenomena with the cosmological constant of Einstein’s general theory of relativity rather than with dark energy.

However, addressing the unresolved issues of dark matter and dark energy remains a priority for many astronomical projects.

In this work, it applied the special theory of relativity to three different space-times in which each of these systems has its own light velocity. It calculates and estimates baryons, dark matter and dark energy by using the chemical reaction rate (stochastic process) and three formulae of the special theory of relativity for the

combined velocity, the increasing mass and the duration time. The results suggest that each of “the ternary space-times” has its own specific light velocity and was created in the inflationary epoch during the very early universe and that the cosmic age of dark matter uncaptured can be about 100 million years in our age of the universe 13.8 billion years. The cosmic age about 100 million years locates in the dark age of universe without any lights.

2. Positioning of the special theory of relativity (from Wikipedia japan “the General theory of relativity”)

In the general theory of relativity, the space-time is mathematically a four-dimensional manifold (Lorentz manifold) in which the tangent vector space of each point is satisfied with Minkowski metrics and Einstein's equations. Thus, the tangent vector space of each point is a Minkowski space according to the special theory of relativity, and the tangent vector space mathematically corresponds to the first-order term of the Taylor expansion.

This means, from the perspective of the general theory of relativity, that *special theory of relativity is a first-order approximation of the general theory of relativity in the vicinity of a single point arbitrarily fixed in the space-time*. Note that each term (curvature, energy/momentum tensor) appearing in Einstein's equations (without cosmic terms) is a term related to quadratic differentiation, and does not appear in the special theory of relativity, which is a first-order approximation.

Conversely, if it looks at the general theory of relativity from the side of the special theory of relativity, the Minkowski space, which is a mathematical formulation of the special theory of relativity, is a flat Lorentz manifold with the same Minkowski metric at all points. ⁴⁾

[Narrowing general relativity to special relativity] From the Internet - EMAN physics "Change in the speed of light" - 2023 p.s.

In the general theory of relativity, "constant speed of light" is no longer a principle, but changes depending on the curvature of the space-time field. However, the result of the general theory is that for every person, he can believe that space-time is flat at only one point where he is located, and he can choose coordinates that will make it so. In other words, as long as he adopts coordinates that match his point of view, he has a "flat space-time under his feet" (narrowing the general theory of relativity to establish the special theory of relativity).

This means that the speed of light passing in front of him is the same for everyone. The same is true for people in the gravitational field. However, when he talks about the speed of light outside of his own location, the value varies from person to person.

As a result, as described in the text below, if the stationary coordinates are at one's feet and the movement of objects A and D is occurring at one's feet, "the special theory of relativity" is established at one's feet. The same applies to the space-time of system 2 and the space-time of system 3. An event occurred in which the space-time of the system 1 ~ system 3 space-time came into contact at one point that overlapped in an extremely rare moment, and dark energy and dark matter (initial inflation) occurred, but it is thought that dark matter was fully generated (big bang) with a delay due to the settling of system 2 space-time.

3. Objects moving at the light velocity

The special theory of relativity is a theory for a constant-velocity inertial frame and is invalid if the observer

moves in an accelerated motion. However, even when the measured person's system is in accelerated motion, the special theory of relativity is valid from the viewpoint of continuous micro-stepped velocity changes in a momentary stationary system, which is the local tangent vector space of the general theory of relativity.

In this paper, it is possible to apply the special theory of relativity if it uses the rest frame in the space-time as a benchmark and checks the relative velocity between two points.

Also, in the relativity theory, since the kinetic mass m of a fast-moving object increases $m = M_0 / \sqrt{1 - v^2/c^2}$ with velocity, the velocity of matter v cannot exceed the light velocity c . However, the relativity theory does not deny that the space-time field itself exceeds the light velocity.

4. Methods

4.1. The combined velocity and the increasing mass

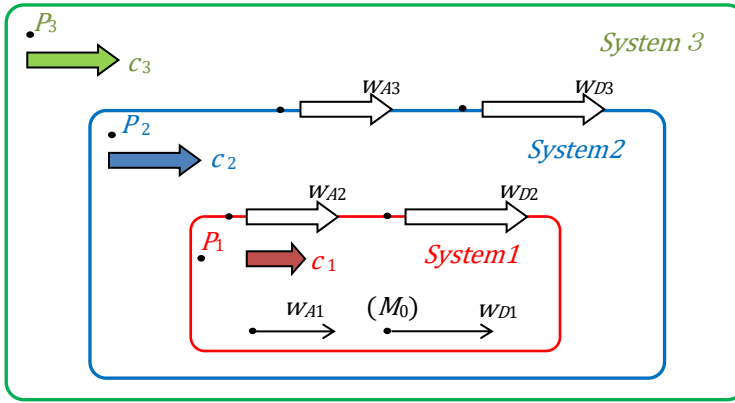

Fig.1 A model of the space-times and the symbols

First, consider applying the special theory of relativity to three different space-times is shown in Fig.1.

P_1 , P_2 and P_3 are the rest frames of the System 1, 2 and 3, respectively. The System 1 space-time moves at the light velocity c_1 in the System 2 space-time, which is the same as the superstring theory. c_2 and c_3 are the same in the System 2 and the System 3 space-times. Galaxy A is the Milky Way galaxy, while galaxy D is a virtual galaxy, the aggregate of all the galaxies in the universe.

Here, c_1 is the light velocity, w_{A1} is the movement speed of galaxy A and w_{D1} is the movement speed of galaxy D in the rest frame P_1 in the System 1 space-time, respectively. c_2, w_{A2}, w_{D2} and c_3, w_{A3}, w_{D3} are the corresponding parameters for the System 2 and the System 3 space-times, respectively. Formulae for the combined velocities of w_{A2}, w_{D2}, w_{A3} and w_{D3} for galaxies A and D in the rest frames P_2 and P_3 are provided as shown below, since the combined velocity law is completed in the accelerated motion and the special theory of relativity is also completed at the flat space-time point where the Systems 1, 2, and 3 come into contact.

$$(1) \quad w_{A2} = \frac{w_{A1} + c_1}{1 + w_{A1} c_1 / c_2^2} \quad w_{D2} = \frac{w_{D1} + c_1}{1 + w_{D1} c_1 / c_2^2} \quad w_{A3} = \frac{w_{A2} + c_2}{1 + w_{A2} c_2 / c_3^2} \quad w_{D3} = \frac{w_{D2} + c_2}{1 + w_{D2} c_2 / c_3^2}$$

The relative speed w_{AD1} between w_{D1} and w_{A1} is presented as shown below when (w_{D1}) and $(-w_{A1})$ are substituted into the combined velocity. The corresponding relative speeds are also shown for the System 2 and the System 3 space-times.

$$(2) \quad w_{AD1} = \frac{w_{D1} - w_{A1}}{1 - w_{A1} w_{D1} / c_1^2} \quad w_{AD2} = \frac{w_{D2} - w_{A2}}{1 - w_{A2} w_{D2} / c_2^2} = \frac{(w_{D1} - w_{A1}) c_2^2}{c_2^2 - w_{A1} w_{D1}}$$

$$w_{AD3} = \frac{w_{D3} - w_{A3}}{1 - w_{A3} w_{D3} / c_3^2} = \frac{(w_{D1} - w_{A1}) c_2^2 c_3^2 (c_2^2 - c_1^2)}{w_{A1} w_{D1} (c_1^2 c_3^2 - c_2^4) + (w_{D1} + w_{A1}) c_1 c_2^2 (c_3^2 - c_2^2) + c_2^4 (c_3^2 - c_1^2)}$$

The rest mass M_0 is common to all three systems and can be described by using the mass of motion m_{D2} at the relative speed w_{AD2} between w_{D2} and w_{A2} in the System 2 space-time. The corresponding descriptions are also provided for both the System 1 and the System 3 space-times.

$$M_0 = m_{D1} \sqrt{1 - \left(\frac{w_{AD1}}{c_1}\right)^2} = m_{D2} \sqrt{1 - \left(\frac{w_{AD2}}{c_2}\right)^2} = m_{D3} \sqrt{1 - \left(\frac{w_{AD3}}{c_3}\right)^2}$$

Substitute w_{AD1} , w_{AD2} and w_{AD3} into the equations.

$$(3) \quad M_0 = m_{D1} \sqrt{1 - \left[\frac{(w_{D1} - w_{A1}) c_1}{c_1^2 - w_{A1} w_{D1}}\right]^2} = m_{D2} \sqrt{1 - \left[\frac{(w_{D1} - w_{A1}) c_2}{c_2^2 - w_{A1} w_{D1}}\right]^2}$$

$$= m_{D3} \sqrt{1 - \left[\frac{(w_{D1} - w_{A1}) c_2^2 c_3 (c_2^2 - c_1^2)}{w_{A1} w_{D1} (c_1^2 c_3^2 - c_2^4) + (w_{D1} + w_{A1}) c_1 c_2^2 (c_3^2 - c_2^2) + c_2^4 (c_3^2 - c_1^2)}\right]^2}$$

It then becomes necessary to solve c_2/c_1 and c_3/c_1 , where $w_{A1} = \alpha \cdot c_1$ and $w_{D1} = \beta \cdot c_1$.

$$\left(\frac{c_2}{c_1}\right)^4 (1 - K) - \left(\frac{c_2}{c_1}\right)^2 [\alpha^2 + \beta^2 - 2\alpha\beta K] + (1 - K)\alpha^2\beta^2 = 0$$

$$(4) \quad \left(\frac{c_2}{c_1}\right) = \delta_2 \sqrt{\frac{1}{2(1 - K)} [\alpha^2 + \beta^2 - 2\alpha\beta K + |\alpha - \beta| \delta_1 \sqrt{(\alpha + \beta)^2 - 4\alpha\beta K}]}$$

$$\left(\frac{c_3}{c_1}\right)^4 (1 - L)(A^2 + \alpha)^2 (A^2 + \beta)^2 - \left(\frac{c_3}{c_1}\right)^2 A^4 [(A^2 - 1)^2 (\alpha - \beta)^2 + 2(1 - L)(A^2 + \alpha)(A^2 + \beta)(1 + \alpha)(1 + \beta)]$$

$$+ (1 - L)A^8 (1 + \alpha)^2 (1 + \beta)^2 = 0$$

$$(5) \quad \left(\frac{c_3}{c_1}\right) = \frac{A^2 \delta_4 \sqrt{(A^2 - 1)^2 (\alpha - \beta)^2 + 2(1 - L)(A^2 + \alpha)(A^2 + \beta)(1 + \alpha)(1 + \beta)} + |A^2 - 1| |\alpha - \beta| \delta_3 \sqrt{(A^2 - 1)^2 (\alpha - \beta)^2 + 4(1 - L)(A^2 + \alpha)(A^2 + \beta)(1 + \alpha)(1 + \beta)}}{(A^2 + \alpha)(A^2 + \beta) \sqrt{2(1 - L)}}$$

where $\delta_1 = \pm 1$, $\delta_2 = \pm 1$, $\delta_3 = \pm 1$ and $\delta_4 = \pm 1$.

$$\text{Here, it inserts } K = \left(\frac{m_{D1}}{m_{D2}}\right)^2 \frac{(1 - \alpha^2)(1 - \beta^2)}{(1 - \alpha\beta)^2} \quad L = \left(\frac{m_{D1}}{m_{D3}}\right)^2 \frac{(1 - \alpha^2)(1 - \beta^2)}{(1 - \alpha\beta)^2} \quad A = \frac{c_2}{c_1}$$

4.2. Mass ratio

Next, I introduce the new variables ε_1 , ε_2 and ε_3 in the forms of $m_{D1} = m\varepsilon_1$, $m_{D2} = m(\varepsilon_1 + \varepsilon_2)$ and $m_{D3} = m(\varepsilon_1 + \varepsilon_2 + \varepsilon_3)$ rather than the variables m_{D1} , m_{D2} and m_{D3} . The mass densities of dark energy, dark matter and baryons are given based on the mass ratio of the galaxy D motion when observed at the Milky Way galaxy A. Therefore, the corresponding mass densities are ε_1 , ε_2 and ε_3 , respectively.

There are $2^4 \times 3! = 96$ possible combinations for the ratios c_2/c_1 and c_3/c_1 .

5. Analysis

5.1. Numerical analysis by computer

The adoption conditions to determine the appropriate solution are described as follows.

- ① The time-space in which dark energy first appears as a result of the system transition has a light velocity with the opposite sign to that of the other two velocities.
- ② The light velocity is faster than any other movement speed of galaxy in any space-time.

$$\text{Then, } |c_3| > |w_{A3}|, |w_{D3}| \quad |c_2| > |w_{A2}|, |w_{D2}| \quad |c_1| > |w_{A1}|, |w_{D1}|.$$

Apply two conditions of the light velocities to 96 combinations. Then six appropriate solutions remain as

shown in Table1 according to the combinations of $\varepsilon_1, \varepsilon_2$ and ε_3 .

- ③ Furthermore, apply the principle of energy minimum in the rest mass-energy E to the System 1, 2 and 3 space-times.

Baryons, dark energy and dark matter appear all together in the System 3 space-time which has the light velocity c_3 (300,000 km/s = c_0) in our real world. This is a boundary condition.

The rest mass-energy E_1 in the System 1 space-time is as follows.

$$E_1 = M_0 c_1^2 = m_{D1} c_1^2 \sqrt{1 - \left(\frac{W_{AD1}}{c_1}\right)^2} = m\varepsilon_1 (c_1/c_3)^2 c_0^2 \sqrt{1 - \left(\frac{W_{AD1}}{c_1}\right)^2}$$

The rest mass-energy E_2 in the System 2 space-time is as follows.

$$(6) \quad E_2 = m(\varepsilon_1 + \varepsilon_2) (c_2/c_3)^2 c_0^2 \sqrt{1 - \left(\frac{W_{AD2}}{c_2}\right)^2}$$

The rest mass-energy E_3 in the System 3 space-time is as follows.

$$E_3 = m(\varepsilon_1 + \varepsilon_2 + \varepsilon_3) c_0^2 \sqrt{1 - \left(\frac{W_{AD3}}{c_3}\right)^2}$$

The calculated rest mass-energy in the System 1,2 and 3 space-times for 6 appropriate solutions is shown in Table 2 to adopt the minimum rest mass-energy.

The most appropriate solution of the minimum rest mass-energy is shown in Table 3 to compare the light velocity ratio in the real world (i.e. the System 3 space-time) with that in the System 1 and 2 space-times.

5.2. Results of numerical analysis

Next, the trial calculations are performed, and the results are discussed below.

Since the absolute value of the galaxy movement speed is unknown, I calculated the light velocities in both the System 2 space-time and the System 3 space-time by changing the galaxy movement speed α, β from -0.999 to $+0.999$ times faster than the light velocity in the System 1 space-time.

There are three requirements as to the physical condition: the light velocity related to the negative pressure based on dark energy is negative, the light velocity is faster than the speed of galaxy, and the rest mass-energy is minimum. In that case, only one combination from 96 possible combinations is left as the most appropriate solution. That is,

$$(\varepsilon_1: \text{baryons, } 0.049; \quad \varepsilon_2: \text{dark energy, } 0.683; \quad \varepsilon_3: \text{dark matter, } 0.268), \quad (\delta_1 = \delta_2 = \delta_3 = -1, \quad \delta_4 = +1).$$

The results of the trial calculations are given in Table 1 and Table 2 with 96 solution samples.

The System 2 space-time has the negative light velocity; in contrast, the System 1 space-time and the System 3 space-time both have the positive light velocities.

The light velocity in the System 1 space-time has the highest value and the absolute light velocity in the System 2 space-time is greater than that in the System 3 space-time.

As a result, equations for the sole appropriate solution are arranged as follows.

$$(7) \quad \left(\frac{c_2}{c_1}\right) = -\sqrt{\frac{1}{2(1-K)} \left[\alpha^2 + \beta^2 - 2\alpha\beta K - |\alpha - \beta| \sqrt{(\alpha + \beta)^2 - 4\alpha\beta K} \right]}$$

$$(8) \quad \left(\frac{c_3}{c_1}\right) = \frac{+A^2 \sqrt{\frac{(A^2 - 1)^2(\alpha - \beta)^2 + 2(1-L)(A^2 + \alpha)(A^2 + \beta)(1 + \alpha)(1 + \beta)}{-|A^2 - 1| |\alpha - \beta| \sqrt{(A^2 - 1)^2(\alpha - \beta)^2 + 4(1-L)(A^2 + \alpha)(A^2 + \beta)(1 + \alpha)(1 + \beta)}}}{(A^2 + \alpha)(A^2 + \beta) \sqrt{2(1-L)}}$$

Table 2 Selection of the appropriate solution satisfied with the condition of light velocity and minimum rest mass energy

| $\varepsilon 1$ | 0.68 dark energy | | | | 0.68 dark energy | | | | 0.27 dark matter | | | | 0.05 baryon | | | | 0.27 dark matter | | | | 0.05 baryon | | | | | | | |
|---------------------------------------|------------------|--------------|--------------|--------------|------------------|--------------|--------------|--------------|------------------|--------------|--------------|--------------|------------------|--------------|--------------|--------------|------------------|--------------|--------------|--------------|------------------|--------------|--------------|--------------|--------------|--------------|--------------|--------------|
| $\varepsilon 2$ | 0.27 dark matter | | | | 0.05 baryon | | | | 0.68 dark energy | | | | 0.68 dark energy | | | | 0.05 baryon | | | | 0.27 dark matter | | | | | | | |
| $\varepsilon 3$ | 0.05 baryon | | | | 0.27 dark matter | | | | 0.05 baryon | | | | 0.27 dark matter | | | | 0.68 dark energy | | | | 0.68 dark energy | | | | | | | |
| c1/c1 | 1.00 | 1.00 | 1.00 | 1.00 | 1.00 | 1.00 | 1.00 | 1.00 | 1.00 | 1.00 | 1.00 | 1.00 | 1.00 | 1.00 | 1.00 | 1.00 | 1.00 | 1.00 | 1.00 | 1.00 | 1.00 | 1.00 | 1.00 | 1.00 | 1.00 | 1.00 | 1.00 | 1.00 |
| $\alpha = Wa1/c1$ | -0.90 | -0.30 | 0.30 | 0.90 | -0.90 | -0.30 | 0.30 | 0.90 | -0.90 | -0.30 | 0.30 | 0.90 | -0.90 | -0.30 | 0.30 | 0.90 | -0.90 | -0.30 | 0.30 | 0.90 | -0.90 | -0.30 | 0.30 | 0.90 | -0.90 | -0.30 | 0.30 | 0.90 |
| $\beta = Wd1/c1$ | -0.90 | -0.90 | -0.90 | -0.90 | -0.90 | -0.90 | -0.90 | -0.90 | -0.90 | -0.90 | -0.90 | -0.90 | -0.90 | -0.90 | -0.90 | -0.90 | -0.90 | -0.90 | -0.90 | -0.90 | -0.90 | -0.90 | -0.90 | -0.90 | -0.90 | -0.90 | -0.90 | -0.90 |
| Wad1/c1 | 0.00 | -0.82 | -0.94 | -0.99 | 0.00 | -0.82 | -0.94 | -0.99 | 0.00 | -0.82 | -0.94 | -0.99 | 0.00 | -0.82 | -0.94 | -0.99 | 0.00 | -0.82 | -0.94 | -0.99 | 0.00 | -0.82 | -0.94 | -0.99 | 0.00 | -0.82 | -0.94 | -0.99 |
| E1/m c₀² | 0.84 | 4527 | 2437 | 0.62 | 0.84 | 5414 | 2867 | 0.90 | 0.33 | 1301 | 744 | 0.09 | 0.06 | 227 | 130 | 0.01 | 0.33 | 1715 | 1000 | 0.30 | 0.06 | 228 | 131 | 0.01 | 0.06 | 228 | 131 | 0.01 |
| c2/c1 | -0.90 | -0.29 | -0.28 | -0.83 | -0.90 | -0.27 | -0.27 | -0.82 | -0.90 | -0.30 | -0.30 | -0.87 | -0.90 | -0.30 | -0.30 | -0.89 | 0.90 | 0.28 | 0.28 | 0.82 | 0.90 | 0.30 | 0.30 | 0.89 | 0.90 | 0.30 | 0.30 | 0.89 |
| Wa2/c1 | -0.90 | -0.26 | 0.28 | 0.83 | -0.90 | -0.24 | 0.26 | 0.81 | -0.90 | -0.29 | 0.30 | 0.87 | -0.90 | -0.30 | 0.30 | 0.89 | -0.90 | -0.25 | 0.27 | 0.82 | -0.90 | -0.30 | 0.30 | 0.88 | -0.90 | -0.30 | 0.30 | 0.88 |
| Wd2/c1 | -0.90 | -0.01 | -0.01 | -0.34 | -0.90 | -0.01 | -0.01 | -0.28 | -0.90 | -0.01 | -0.01 | -0.56 | -0.90 | -0.01 | -0.01 | -0.79 | -0.90 | -0.01 | -0.01 | -0.31 | -0.90 | -0.01 | -0.01 | -0.68 | -0.90 | -0.01 | -0.01 | -0.68 |
| Wad2/c1 | 0/0 | 0.26 | -0.28 | -0.83 | 0/0 | 0.23 | -0.26 | -0.81 | 0/0 | 0.29 | -0.30 | -0.87 | 0/0 | 0.30 | -0.30 | -0.89 | 0/0 | 0.25 | -0.27 | -0.82 | 0/0 | 0.30 | -0.30 | -0.89 | 0/0 | 0.30 | -0.30 | -0.89 |
| E2/m c₀² | #VALUE! | 371 | 197 | 0.43 | #VALUE! | 408 | 215 | 0.60 | #VALUE! | 116 | 65.85 | 0.07 | #VALUE! | 20.38 | 11.71 | 0.01 | #VALUE! | 134 | 77.38 | 0.20 | #VALUE! | 20.46 | 11.77 | 0.01 | #VALUE! | 20.46 | 11.77 | 0.01 |
| c3/c1 | -0.90 | -0.01 | -0.01 | -0.34 | -0.90 | -0.01 | -0.01 | -0.28 | 0.90 | 0.01 | 0.01 | 0.56 | 0.90 | 0.01 | 0.01 | 0.79 | -0.90 | -0.01 | -0.01 | -0.31 | -0.90 | -0.01 | -0.01 | -0.68 | -0.90 | -0.01 | -0.01 | -0.68 |
| Wa3/c1 | -0.90 | 0.00 | 0.00 | 0.00 | -0.90 | 0.00 | 0.00 | 0.00 | -0.90 | 0.00 | 0.00 | 0.00 | -0.90 | 0.00 | 0.00 | 0.00 | -0.90 | 0.00 | 0.00 | 0.20 | -0.90 | 0.00 | 0.00 | 0.65 | -0.90 | 0.00 | 0.00 | 0.65 |
| Wd3/c1 | -0.90 | -0.01 | -0.01 | -0.34 | -0.90 | -0.01 | -0.01 | -0.28 | -0.90 | -0.01 | -0.01 | -0.56 | -0.90 | -0.01 | -0.01 | -0.79 | -0.90 | -0.01 | -0.01 | -0.30 | -0.90 | -0.01 | -0.01 | -0.68 | -0.90 | -0.01 | -0.01 | -0.68 |
| Wad3/c1 | 0/0 | -0.01 | -0.01 | -0.34 | 0/0 | -0.01 | -0.01 | -0.28 | 0/0 | -0.01 | -0.01 | -0.56 | 0/0 | -0.01 | -0.01 | -0.79 | 0/0 | -0.01 | -0.01 | -0.30 | 0/0 | -0.01 | -0.01 | -0.68 | 0/0 | -0.01 | -0.01 | -0.68 |
| E3/m c₀² | #VALUE! | 0.39 | 0.22 | 0.07 | #VALUE! | 0.39 | 0.22 | 0.07 | #VALUE! | 0.15 | 0.09 | 0.03 | #VALUE! | 0.03 | 0.02 | 0.01 | #VALUE! | 0.15 | 0.09 | 0.03 | #VALUE! | 0.03 | 0.02 | 0.01 | #VALUE! | 0.03 | 0.02 | 0.01 |
| c1/c1 | 1.00 | 1.00 | 1.00 | 1.00 | 1.00 | 1.00 | 1.00 | 1.00 | 1.00 | 1.00 | 1.00 | 1.00 | 1.00 | 1.00 | 1.00 | 1.00 | 1.00 | 1.00 | 1.00 | 1.00 | 1.00 | 1.00 | 1.00 | 1.00 | 1.00 | 1.00 | 1.00 | 1.00 |
| $\alpha = Wa1/c1$ | -0.90 | -0.30 | 0.30 | 0.90 | -0.90 | -0.30 | 0.30 | 0.90 | -0.90 | -0.30 | 0.30 | 0.90 | -0.90 | -0.30 | 0.30 | 0.90 | -0.90 | -0.30 | 0.30 | 0.90 | -0.90 | -0.30 | 0.30 | 0.90 | -0.90 | -0.30 | 0.30 | 0.90 |
| $\beta = Wd1/c1$ | -0.30 | -0.30 | -0.30 | -0.30 | -0.30 | -0.30 | -0.30 | -0.30 | -0.30 | -0.30 | -0.30 | -0.30 | -0.30 | -0.30 | -0.30 | -0.30 | -0.30 | -0.30 | -0.30 | -0.30 | -0.30 | -0.30 | -0.30 | -0.30 | -0.30 | -0.30 | -0.30 | -0.30 |
| Wad1/c1 | 0.82 | 0.00 | -0.55 | -0.94 | 0.82 | 0.00 | -0.55 | -0.94 | 0.82 | 0.00 | -0.55 | -0.94 | 0.82 | 0.00 | -0.55 | -0.94 | 0.82 | 0.00 | -0.55 | -0.94 | 0.82 | 0.00 | -0.55 | -0.94 | 0.82 | 0.00 | -0.55 | -0.94 |
| E1/m c₀² | 4527 | 7.59 | 443 | 10.95 | 5414 | 7.59 | 1863 | 12.66 | 1301 | 2.98 | 11.54 | 3.12 | 227 | 0.54 | 0.65 | 0.54 | 1715 | 2.98 | 183 | 4.00 | 228 | 0.54 | 0.94 | 0.54 | 228 | 0.54 | 0.94 | 0.54 |
| c2/c1 | -0.29 | -0.30 | -0.15 | -0.28 | -0.27 | -0.30 | -0.11 | -0.27 | -0.30 | -0.30 | -0.24 | -0.30 | -0.30 | -0.30 | -0.28 | -0.30 | 0.28 | 0.30 | 0.12 | 0.28 | 0.30 | 0.30 | 0.26 | 0.30 | 0.30 | 0.30 | 0.26 | 0.30 |
| Wa2/c1 | -0.01 | -0.30 | 0.09 | 0.16 | -0.01 | -0.30 | 0.05 | 0.15 | -0.01 | -0.30 | 0.20 | 0.17 | -0.01 | -0.30 | 0.27 | 0.17 | -0.01 | -0.30 | 0.06 | 0.15 | -0.01 | -0.30 | 0.24 | 0.17 | -0.01 | -0.30 | 0.24 | 0.17 |
| Wd2/c1 | -0.26 | -0.30 | -0.06 | -0.26 | -0.24 | -0.30 | -0.03 | -0.23 | -0.29 | -0.30 | -0.16 | -0.29 | -0.30 | -0.30 | -0.26 | -0.30 | -0.25 | -0.30 | -0.04 | -0.24 | -0.30 | -0.30 | -0.21 | -0.30 | -0.30 | -0.30 | -0.21 | -0.30 |
| Wad2/c1 | -0.26 | 0/0 | -0.12 | -0.28 | -0.23 | 0/0 | -0.07 | -0.26 | -0.29 | 0/0 | -0.23 | -0.30 | -0.30 | 0/0 | -0.28 | -0.30 | -0.25 | 0/0 | -0.09 | -0.27 | -0.30 | 0/0 | -0.26 | -0.30 | -0.30 | 0/0 | -0.26 | -0.30 |
| E2/m c₀² | 371 | #VALUE! | 9.98 | 0.88 | 408 | #VALUE! | 20.83 | 0.95 | 116 | #VALUE! | 0.64 | 0.28 | 20.38 | #VALUE! | 0.05 | 0.05 | 134 | #VALUE! | 2.84 | 0.31 | 20.46 | #VALUE! | 0.07 | 0.05 | 20.46 | #VALUE! | 0.07 | 0.05 |
| c3/c1 | -0.01 | -0.30 | -0.04 | -0.14 | -0.01 | -0.30 | -0.02 | -0.13 | 0.01 | 0.30 | 0.14 | 0.17 | 0.01 | 0.30 | 0.25 | 0.17 | -0.01 | -0.30 | -0.03 | -0.15 | -0.01 | -0.30 | -0.21 | -0.17 | -0.01 | -0.30 | -0.21 | -0.17 |
| Wa3/c1 | -0.01 | -0.30 | 0.01 | 0.11 | -0.01 | -0.30 | 0.00 | 0.10 | -0.01 | -0.30 | 0.02 | 0.16 | -0.01 | -0.30 | 0.04 | 0.17 | -0.01 | -0.30 | 0.03 | 0.15 | -0.01 | -0.30 | 0.20 | 0.17 | -0.01 | -0.30 | 0.20 | 0.17 |
| Wd3/c1 | 0.00 | -0.30 | -0.03 | -0.12 | 0.00 | -0.30 | -0.01 | -0.11 | 0.00 | -0.30 | -0.13 | -0.14 | 0.00 | -0.30 | -0.25 | -0.15 | 0.00 | -0.30 | -0.03 | -0.02 | 0.00 | -0.30 | -0.19 | 0.00 | 0.00 | -0.30 | -0.19 | 0.00 |
| Wad3/c1 | 0.01 | 0/0 | -0.03 | -0.14 | 0.01 | 0/0 | -0.01 | -0.13 | 0.01 | 0/0 | -0.14 | -0.17 | 0.01 | 0/0 | -0.25 | -0.17 | 0.01 | 0/0 | -0.03 | -0.15 | 0.01 | 0/0 | -0.21 | -0.17 | 0.01 | 0/0 | -0.21 | -0.17 |
| E3/m c₀² | 0.39 | #VALUE! | 0.57 | 0.22 | 0.39 | #VALUE! | 0.57 | 0.22 | 0.15 | #VALUE! | 0.22 | 0.09 | 0.03 | #VALUE! | 0.04 | 0.02 | 0.15 | #VALUE! | 0.22 | 0.09 | 0.03 | #VALUE! | 0.04 | 0.02 | 0.03 | #VALUE! | 0.04 | 0.02 |
| c1/c1 | 1.00 | 1.00 | 1.00 | 1.00 | 1.00 | 1.00 | 1.00 | 1.00 | 1.00 | 1.00 | 1.00 | 1.00 | 1.00 | 1.00 | 1.00 | 1.00 | 1.00 | 1.00 | 1.00 | 1.00 | 1.00 | 1.00 | 1.00 | 1.00 | 1.00 | 1.00 | 1.00 | 1.00 |
| $\alpha = Wa1/c1$ | -0.90 | -0.30 | 0.30 | 0.90 | -0.90 | -0.30 | 0.30 | 0.90 | -0.90 | -0.30 | 0.30 | 0.90 | -0.90 | -0.30 | 0.30 | 0.90 | -0.90 | -0.30 | 0.30 | 0.90 | -0.90 | -0.30 | 0.30 | 0.90 | -0.90 | -0.30 | 0.30 | 0.90 |
| $\beta = Wd1/c1$ | 0.30 | 0.30 | 0.30 | 0.30 | 0.30 | 0.30 | 0.30 | 0.30 | 0.30 | 0.30 | 0.30 | 0.30 | 0.30 | 0.30 | 0.30 | 0.30 | 0.30 | 0.30 | 0.30 | 0.30 | 0.30 | 0.30 | 0.30 | 0.30 | 0.30 | 0.30 | 0.30 | 0.30 |
| Wad1/c1 | 0.94 | 0.55 | 0.00 | -0.82 | 0.94 | 0.55 | 0.00 | -0.82 | 0.94 | 0.55 | 0.00 | -0.82 | 0.94 | 0.55 | 0.00 | -0.82 | 0.94 | 0.55 | 0.00 | -0.82 | 0.94 | 0.55 | 0.00 | -0.82 | 0.94 | 0.55 | 0.00 | -0.82 |
| E1/m c₀² | 2437 | 443 | 7.59 | 16.25 | 2867 | 1863 | 7.59 | 18.90 | 744 | 11.54 | 2.98 | 5.27 | 130 | 0.65 | 0.54 | 0.94 | 1000 | 183 | 2.98 | 6.64 | 131 | 0.94 | 0.54 | 0.94 | 131 | 0.94 | 0.54 | 0.94 |
| c2/c1 | -0.28 | -0.15 | -0.30 | -0.29 | -0.27 | -0.11 | -0.30 | -0.27 | -0.30 | -0.24 | -0.30 | -0.30 | -0.30 | -0.28 | -0.30 | -0.30 | 0.28 | 0.12 | 0.30 | 0.28 | 0.30 | 0.26 | 0.30 | 0.30 | 0.30 | 0.26 | 0.30 | 0.30 |
| Wa2/c1 | -0.01 | -0.06 | 0.30 | 0.16 | -0.01 | -0.03 | 0.30 | 0.15 | -0.01 | -0.16 | 0.30 | 0.17 | -0.01 | -0.26 | 0.30 | 0.17 | -0.01 | -0.04 | 0.30 | 0.15 | -0.01 | -0.21 | 0.30 | 0.17 | -0.01 | -0.21 | 0.30 | 0.17 |
| Wd2/c1 | 0.28 | 0.09 | 0.30 | 0.28 | 0.26 | 0.05 | 0.30 | 0.26 | 0.30 | 0.20 | 0.30 | 0.30 | 0.30 | 0.27 | 0.30 | 0.30 | 0.27 | 0.06 | 0.30 | 0.27 | 0.30 | 0.24 | 0.30 | 0.30 | 0.30 | 0.24 | 0.30 | 0.30 |
| Wad2/c1 | 0.28 | 0.12 | 0/0 | 0.26 | 0.26 | 0.07 | 0/0 | 0.23 | 0.30 | 0.23 | 0/0 | 0.29 | 0.30 | 0.28 | 0/0 | 0.30 | 0.27 | 0.09 | 0/0 | 0.25 | 0.30 | 0.26 | 0/0 | 0.30 | 0.30 | 0.26 | 0/0 | 0.30 |
| E2/m c₀² | 197 | 9.98 | #VALUE! | 1.33 | 215 | 20.83 | #VALUE! | 1.43 | 65.85 | 0.64 | #VALUE! | 0.47 | | | | | | | | | | | | | | | | |

Table 3 Light velocity ratio between in Real World and in the System 1 and 2 of the appropriate solution ($-0.9 < \alpha < 0.9, -0.9 < \beta < 0.9$)

| | | | | | | | | | | | | | | | | | |
|-------------------|--------------|--------------|--------------|--------------|--------------|--------------|--------------|--------------|--------------|--------------|--------------|--------------|--------------|--------------|--------------|--------------|-------------|
| c1/c1 | 1.00 | 1.00 | 1.00 | 1.00 | 1.00 | 1.00 | 1.00 | 1.00 | 1.00 | 1.00 | 1.00 | 1.00 | 1.00 | 1.00 | 1.00 | 1.00 | 1.00 |
| $\alpha = Wa1/c1$ | -0.90 | -0.60 | -0.30 | -0.10 | 0.10 | 0.30 | 0.60 | 0.90 | -0.90 | -0.60 | -0.30 | -0.10 | 0.10 | 0.30 | 0.60 | 0.90 | |
| $\beta = Wd1/c1$ | -0.90 | -0.90 | -0.90 | -0.90 | -0.90 | -0.90 | -0.90 | -0.90 | -0.60 | -0.60 | -0.60 | -0.60 | -0.60 | -0.60 | -0.60 | -0.60 | -0.60 |
| Wad1/c1 | 0.00 | -0.65 | -0.82 | -0.88 | -0.92 | -0.94 | -0.97 | -0.99 | 0.65 | 0.00 | -0.37 | -0.53 | -0.66 | -0.76 | -0.88 | -0.97 | |
| c1/c3 | 1.1 | 15.0 | 90.1 | 891 | 891 | 90.1 | 15.0 | 1.3 | 15.0 | 1.7 | 14.2 | 148 | 148 | 14.3 | 1.9 | 1.8 | |
| c2/c1 | -0.90 | -0.60 | -0.30 | -0.10 | -0.10 | -0.30 | -0.60 | -0.89 | -0.60 | -0.60 | -0.30 | -0.10 | -0.10 | -0.30 | -0.58 | -0.60 | |
| Wa2/c1 | -0.90 | -0.60 | -0.30 | -0.10 | 0.10 | 0.30 | 0.60 | 0.89 | -0.07 | -0.60 | -0.30 | -0.10 | 0.10 | 0.30 | 0.58 | 0.54 | |
| Wd2/c1 | -0.90 | -0.07 | -0.01 | 0.00 | 0.00 | -0.01 | -0.07 | -0.79 | -0.60 | -0.60 | -0.07 | -0.01 | -0.01 | -0.07 | -0.52 | -0.60 | |
| Wad2/c1 | 0/0 | 0.60 | 0.30 | 0.10 | -0.10 | -0.30 | -0.60 | -0.89 | -0.60 | 0/0 | 0.30 | 0.10 | -0.10 | -0.30 | -0.58 | -0.60 | |
| c2/c3 | -1.0 | -9.0 | -27.0 | -89.1 | -89.1 | -27.0 | -9.0 | -1.1 | -9.0 | -1.0 | -4.3 | -14.8 | -14.8 | -4.3 | -1.1 | -1.1 | |
| c3/c1 | 0.90 | 0.07 | 0.01 | 0.00 | 0.00 | 0.01 | 0.07 | 0.79 | 0.07 | 0.60 | 0.07 | 0.01 | 0.01 | 0.07 | 0.51 | 0.54 | |
| Wa3/c1 | -0.90 | -0.01 | 0.00 | 0.00 | 0.00 | 0.00 | 0.00 | 0.00 | -0.07 | -0.60 | -0.03 | 0.00 | 0.00 | 0.00 | 0.02 | 0.53 | |
| Wd3/c1 | -0.90 | -0.07 | -0.01 | 0.00 | 0.00 | -0.01 | -0.07 | -0.79 | -0.01 | -0.60 | -0.07 | -0.01 | -0.01 | -0.07 | -0.51 | -0.54 | |
| Wad3/c1 | 0/0 | -0.07 | -0.01 | 0.00 | 0.00 | -0.01 | -0.07 | -0.79 | 0.07 | 0/0 | -0.07 | -0.01 | -0.01 | -0.07 | -0.51 | -0.54 | |
| c3/c3 | 1.00 | 1.00 | 1.00 | 1.00 | 1.00 | 1.00 | 1.00 | 1.00 | 1.00 | 1.00 | 1.00 | 1.00 | 1.00 | 1.00 | 1.00 | 1.00 | 1.00 |
| c1/c1 | 1.00 | 1.00 | 1.00 | 1.00 | 1.00 | 1.00 | 1.00 | 1.00 | 1.00 | 1.00 | 1.00 | 1.00 | 1.00 | 1.00 | 1.00 | 1.00 | 1.00 |
| $\alpha = Wa1/c1$ | -0.90 | -0.60 | -0.30 | -0.10 | 0.10 | 0.30 | 0.60 | 0.90 | -0.90 | -0.60 | -0.30 | -0.10 | 0.10 | 0.30 | 0.60 | 0.90 | |
| $\beta = Wd1/c1$ | -0.30 | -0.30 | -0.30 | -0.30 | -0.30 | -0.30 | -0.30 | -0.30 | -0.10 | -0.10 | -0.10 | -0.10 | -0.10 | -0.10 | -0.10 | -0.10 | -0.10 |
| Wad1/c1 | 0.82 | 0.37 | 0.00 | -0.21 | -0.39 | -0.55 | -0.76 | -0.94 | 0.88 | 0.53 | 0.21 | 0.00 | -0.20 | -0.39 | -0.66 | -0.92 | |
| c1/c3 | 90.1 | 14.2 | 3.3 | 41.6 | 41.8 | 4.0 | 4.8 | 5.8 | 891 | 148 | 41.6 | 10.0 | 12.0 | 24.1 | 38.3 | 48.0 | |
| c2/c1 | -0.30 | -0.30 | -0.30 | -0.10 | -0.10 | -0.28 | -0.30 | -0.30 | -0.10 | -0.10 | -0.10 | -0.10 | -0.09 | -0.10 | -0.10 | -0.10 | |
| Wa2/c1 | -0.01 | -0.07 | -0.30 | -0.10 | 0.10 | 0.27 | 0.21 | 0.17 | 0.00 | -0.01 | -0.02 | -0.10 | 0.09 | 0.04 | 0.03 | 0.02 | |
| Wd2/c1 | -0.30 | -0.30 | -0.30 | -0.02 | -0.02 | -0.26 | -0.30 | -0.30 | -0.10 | -0.10 | -0.10 | -0.10 | -0.09 | -0.10 | -0.10 | -0.10 | |
| Wad2/c1 | -0.30 | -0.30 | 0/0 | 0.10 | -0.10 | -0.28 | -0.30 | -0.30 | -0.10 | -0.10 | -0.10 | 0/0 | -0.09 | -0.10 | -0.10 | -0.10 | |
| c2/c3 | -27.0 | -4.3 | -1.0 | -4.2 | -4.2 | -1.1 | -1.4 | -1.7 | -89.1 | -14.8 | -4.2 | -1.0 | -1.1 | -2.4 | -3.8 | -4.8 | |
| c3/c1 | 0.01 | 0.07 | 0.30 | 0.02 | 0.02 | 0.25 | 0.21 | 0.17 | 0.00 | 0.01 | 0.02 | 0.10 | 0.08 | 0.04 | 0.03 | 0.02 | |
| Wa3/c1 | -0.01 | -0.07 | -0.30 | -0.01 | 0.00 | 0.04 | 0.20 | 0.17 | 0.00 | -0.01 | -0.02 | -0.10 | 0.03 | 0.04 | 0.03 | 0.02 | |
| Wd3/c1 | 0.00 | -0.03 | -0.30 | -0.02 | -0.02 | -0.25 | -0.19 | -0.15 | 0.00 | 0.00 | -0.01 | -0.10 | -0.08 | -0.03 | -0.01 | -0.01 | |
| Wad3/c1 | 0.01 | 0.07 | 0/0 | -0.02 | -0.02 | -0.25 | -0.21 | -0.17 | 0.00 | 0.01 | 0.02 | 0/0 | -0.08 | -0.04 | -0.03 | -0.02 | |
| c3/c3 | 1.00 | 1.00 | 1.00 | 1.00 | 1.00 | 1.00 | 1.00 | 1.00 | 1.00 | 1.00 | 1.00 | 1.00 | 1.00 | 1.00 | 1.00 | 1.00 | 1.00 |
| c1/c1 | 1.00 | 1.00 | 1.00 | 1.00 | 1.00 | 1.00 | 1.00 | 1.00 | 1.00 | 1.00 | 1.00 | 1.00 | 1.00 | 1.00 | 1.00 | 1.00 | 1.00 |
| $\alpha = Wa1/c1$ | -0.90 | -0.60 | -0.30 | -0.10 | 0.10 | 0.30 | 0.60 | 0.90 | -0.90 | -0.60 | -0.30 | -0.10 | 0.10 | 0.30 | 0.60 | 0.90 | |
| $\beta = Wd1/c1$ | 0.10 | 0.10 | 0.10 | 0.10 | 0.10 | 0.10 | 0.10 | 0.10 | 0.30 | 0.30 | 0.30 | 0.30 | 0.30 | 0.30 | 0.30 | 0.30 | 0.30 |
| Wad1/c1 | 0.92 | 0.66 | 0.39 | 0.20 | 0.00 | -0.21 | -0.53 | -0.88 | 0.94 | 0.76 | 0.55 | 0.39 | 0.21 | 0.00 | -0.37 | -0.82 | |
| c1/c3 | 891 | 148 | 41.8 | 12.0 | 10.0 | 23.9 | 38.2 | 47.9 | 90.1 | 14.3 | 4.0 | 24.1 | 23.9 | 3.3 | 4.8 | 5.8 | |
| c2/c1 | -0.10 | -0.10 | -0.10 | -0.09 | -0.10 | -0.10 | -0.10 | -0.10 | -0.30 | -0.30 | -0.28 | -0.10 | -0.10 | -0.30 | -0.30 | -0.30 | |
| Wa2/c1 | 0.00 | -0.01 | -0.02 | -0.09 | 0.10 | 0.04 | 0.03 | 0.02 | -0.01 | -0.07 | -0.26 | -0.10 | 0.10 | 0.30 | 0.21 | 0.17 | |
| Wd2/c1 | 0.10 | 0.10 | 0.10 | 0.09 | 0.10 | 0.10 | 0.10 | 0.10 | 0.30 | 0.30 | 0.27 | 0.04 | 0.04 | 0.30 | 0.30 | 0.30 | |
| Wad2/c1 | 0.10 | 0.10 | 0.10 | 0.09 | 0/0 | 0.10 | 0.10 | 0.10 | 0.30 | 0.30 | 0.28 | 0.10 | -0.10 | 0/0 | 0.30 | 0.30 | |
| c2/c3 | -89.1 | -14.8 | -4.2 | -1.1 | -1.0 | -2.4 | -3.8 | -4.8 | -27.0 | -4.3 | -1.1 | -2.4 | -2.4 | -1.0 | -1.4 | -1.7 | |
| c3/c1 | 0.00 | 0.01 | 0.02 | 0.08 | 0.10 | 0.04 | 0.03 | 0.02 | 0.01 | 0.07 | 0.25 | 0.04 | 0.04 | 0.30 | 0.21 | 0.17 | |
| Wa3/c1 | 0.00 | -0.01 | -0.02 | -0.08 | 0.10 | 0.04 | 0.03 | 0.02 | -0.01 | -0.07 | -0.25 | -0.03 | 0.00 | 0.30 | 0.21 | 0.17 | |
| Wd3/c1 | 0.00 | 0.00 | 0.00 | 0.03 | 0.10 | 0.00 | 0.00 | 0.00 | 0.00 | 0.00 | 0.04 | 0.04 | 0.04 | 0.30 | 0.00 | 0.00 | |
| Wad3/c1 | 0.00 | 0.01 | 0.02 | 0.08 | 0/0 | -0.04 | -0.03 | -0.02 | 0.01 | 0.07 | 0.25 | 0.04 | 0.04 | 0/0 | -0.21 | -0.17 | |
| c3/c3 | 1.00 | 1.00 | 1.00 | 1.00 | 1.00 | 1.00 | 1.00 | 1.00 | 1.00 | 1.00 | 1.00 | 1.00 | 1.00 | 1.00 | 1.00 | 1.00 | 1.00 |
| c1/c1 | 1.00 | 1.00 | 1.00 | 1.00 | 1.00 | 1.00 | 1.00 | 1.00 | 1.00 | 1.00 | 1.00 | 1.00 | 1.00 | 1.00 | 1.00 | 1.00 | 1.00 |
| $\alpha = Wa1/c1$ | -0.90 | -0.60 | -0.30 | -0.10 | 0.10 | 0.30 | 0.60 | 0.90 | -0.90 | -0.60 | -0.30 | -0.10 | 0.10 | 0.30 | 0.60 | 0.90 | |
| $\beta = Wd1/c1$ | 0.60 | 0.60 | 0.60 | 0.60 | 0.60 | 0.60 | 0.60 | 0.60 | 0.90 | 0.90 | 0.90 | 0.90 | 0.90 | 0.90 | 0.90 | 0.90 | 0.90 |
| Wad1/c1 | 0.97 | 0.88 | 0.76 | 0.66 | 0.53 | 0.37 | 0.00 | -0.65 | 0.99 | 0.97 | 0.94 | 0.92 | 0.88 | 0.82 | 0.65 | 0.00 | |
| c1/c3 | 15.0 | 1.9 | 4.8 | 38.3 | 38.2 | 4.8 | 1.7 | 1.8 | 1.3 | 1.8 | 5.8 | 48.0 | 47.9 | 5.8 | 1.8 | 1.1 | |
| c2/c1 | -0.60 | -0.58 | -0.30 | -0.10 | -0.10 | -0.30 | -0.60 | -0.60 | -0.89 | -0.60 | -0.30 | -0.10 | -0.10 | -0.30 | -0.60 | -0.90 | |
| Wa2/c1 | -0.07 | -0.52 | -0.30 | -0.10 | 0.10 | 0.30 | 0.60 | 0.54 | -0.79 | -0.60 | -0.30 | -0.10 | 0.10 | 0.30 | 0.60 | 0.90 | |
| Wd2/c1 | 0.60 | 0.58 | 0.21 | 0.03 | 0.03 | 0.21 | 0.60 | 0.60 | 0.89 | 0.54 | 0.17 | 0.02 | 0.02 | 0.17 | 0.54 | 0.90 | |
| Wad2/c1 | 0.60 | 0.58 | 0.30 | 0.10 | -0.10 | -0.30 | 0/0 | 0.60 | 0.89 | 0.60 | 0.30 | 0.10 | -0.10 | -0.30 | -0.60 | 0/0 | |
| c2/c3 | -9.0 | -1.1 | -1.4 | -3.8 | -3.8 | -1.4 | -1.0 | -1.1 | -1.1 | -1.1 | -1.7 | -4.8 | -4.8 | -1.7 | -1.1 | -1.0 | |
| c3/c1 | 0.07 | 0.51 | 0.21 | 0.03 | 0.03 | 0.21 | 0.60 | 0.54 | 0.79 | 0.54 | 0.17 | 0.02 | 0.02 | 0.17 | 0.54 | 0.90 | |
| Wa3/c1 | -0.07 | -0.51 | -0.19 | -0.01 | 0.00 | 0.00 | 0.60 | 0.54 | -0.79 | -0.54 | -0.15 | -0.01 | 0.00 | 0.00 | 0.00 | 0.90 | |
| Wd3/c1 | 0.00 | 0.02 | 0.20 | 0.03 | 0.03 | 0.21 | 0.60 | 0.00 | 0.00 | 0.53 | 0.17 | 0.02 | 0.02 | 0.17 | 0.54 | 0.90 | |
| Wad3/c1 | 0.07 | 0.51 | 0.21 | 0.03 | 0.03 | 0.21 | 0/0 | -0.54 | 0.79 | 0.54 | 0.17 | 0.02 | 0.02 | 0.17 | 0.54 | 0/0 | |
| c3/c3 | 1.00 | 1.00 | 1.00 | 1.00 | 1.00 | 1.00 | 1.00 | 1.00 | 1.00 | 1.00 | 1.00 | 1.00 | 1.00 | 1.00 | 1.00 | 1.00 | 1.00 |

Here, it inserts $K = \left(\frac{\varepsilon_1}{\varepsilon_1 + \varepsilon_2}\right)^2 \frac{(1-\alpha^2)(1-\beta^2)}{(1-\alpha\beta)^2}$ $L = \left(\frac{\varepsilon_1}{\varepsilon_1 + \varepsilon_2 + \varepsilon_3}\right)^2 \frac{(1-\alpha^2)(1-\beta^2)}{(1-\alpha\beta)^2}$ $A = \frac{c_2}{c_1}$

ε_1 : baryons, 0.049 ε_2 : dark energy, 0.683 ε_3 : dark matter, 0.268

$\alpha = w_{A1}/c_1$, $\beta = w_{D1}/c_1$

By changing the speed of galaxy movement α and β from -0.9 to $+0.9$ times faster than the light velocity c_1 as some examples, c_2/c_1 changes from -0.9 to -0.1 times and c_3/c_1 changes from 0 to 0.9 times i.e., $c_1 > |c_2| > c_3$.

5.3. Denying the presence of the System 4 space-time

Since the System 1, 2 and 3 space-times exist, it is highly likely that the System 4 space-time also similarly exists. This calls for investigating the possibility of the System 4 space-time existence.

Apply the formula of "4.1. The combined velocity and the increasing mass" to the System 4 space-time.

$$w_{A4} = \frac{w_{A3} + c_3}{1 + w_{A3} c_3 / c_4^2} \quad w_{D4} = \frac{w_{D3} + c_3}{1 + w_{D3} c_3 / c_4^2}$$

The relative speed w_{AD4} between w_{A4} and w_{D4} is presented as shown below when (w_{D4}) and $(-w_{A4})$ are substituted into the combined velocity.

$$w_{AD4} = \frac{w_{D4} - w_{A4}}{1 - w_{A4} w_{D4} / c_4^2} = \frac{(w_{D1} - w_{A1}) c_2^2 c_3^2 c_4^2 (c_2^2 - c_1^2)(c_3^2 - c_2^2)}{\left[c_4^2 [c_2^2 (c_3^2 + c_1 c_2) + w_{A1} (c_2^3 + c_1 c_3^2)] [c_2^2 (c_3^2 + c_1 c_2) + w_{D1} (c_2^3 + c_1 c_3^2)] \right] - c_2^2 c_3^4 (c_1 + c_2)^2 (w_{A1} + c_2)(w_{D1} + c_2)}$$

The rest mass M_0 is common to all four systems and can be described by using the mass of motion m_{D4} at the relative speed w_{AD4} .

$$M_0 = m_{D1} \sqrt{1 - \left(\frac{w_{AD1}}{c_1}\right)^2} = m_{D2} \sqrt{1 - \left(\frac{w_{AD2}}{c_2}\right)^2} = m_{D3} \sqrt{1 - \left(\frac{w_{AD3}}{c_3}\right)^2} = m_{D4} \sqrt{1 - \left(\frac{w_{AD4}}{c_4}\right)^2}$$

Substitute w_{AD1} , w_{AD2} , w_{AD3} and w_{AD4} into the equations.

It then becomes necessary to solve the quadratic equation of c_4 , where $w_{A1} = \alpha \cdot c_1$, $w_{D1} = \beta \cdot c_1$ and

$$J = \left(\frac{m_{D1}}{m_{D4}}\right)^2 \frac{(1-\alpha^2)(1-\beta^2)}{(1-\alpha\beta)^2} = 1 - \left(\frac{w_{AD4}}{c_4}\right)^2$$

There are four solutions of c_4 , which are $\delta_5 = \pm 1$, $\delta_6 = \pm 1$. $c_4 = (-b + \delta_6 \sqrt{b^2 - 4ac})/2a$

$$c_4^2 \delta_5 \sqrt{1-J} [c_1 c_2^3 (1+\alpha) + c_3^2 (c_2^2 + \alpha c_1^2)] [c_1 c_2^3 (1+\beta) + c_3^2 (c_2^2 + \beta c_1^2)] + c_4 (\alpha - \beta) c_1 c_2^2 c_3^2 (c_2^2 - c_1^2)(c_3^2 - c_2^2) - \delta_5 \sqrt{1-J} c_2^2 c_3^4 (c_1 + c_2)^2 (\alpha c_1 + c_2)(\beta c_1 + c_2) = 0$$

Vary α and β from -0.9 to $+0.9$, respectively as numerical analyses. Set each parameter in the System 4 space-time as follows: baryons $\varepsilon_1=0.049$, dark energy $\varepsilon_2=0.683$, dark matter $\varepsilon_3=0.268$ and the unknown energy body ε_4 from 0 to 0.1 . The light velocities c_1 , c_2 and c_3 are adopted according to "5.2. Results".

The results of numerical analyses show that the sign of c_4/c_1 of any δ_5 and δ_6 transits to \pm when α and β vary from -0.9 to $+0.9$. A trial calculation example is shown in table 4.

This indicates that the characteristics of the System 4 space-time are uncertain and as a result, the System 4 space-time itself and the fourary space-times do not exist.

Table 4 Trial calculation example of the light velocity in the System 4 space-time

(in the case of $\epsilon_4=0.01, \delta_5=\delta_6=1$)

| $\beta=W_{d1}/c_1$ | $\alpha=W_{a1}/c_1$ | -0.9 | -0.3 | 0.3 | 0.9 |
|--------------------|---------------------|--------|--------|---------------|---------------|
| -0.9 | c1/c1 | 1.000 | 1.000 | 1.000 | 1.000 |
| | c2/c1 | -0.900 | -0.300 | -0.300 | -0.894 |
| | c3/c1 | 0.900 | 0.011 | 0.011 | 0.788 |
| | c4/c1 | 0.900 | 0.001 | 0.000 | -0.001 |
| -0.3 | c1/c1 | 1.000 | 1.000 | 1.000 | 1.000 |
| | c2/c1 | -0.300 | -0.300 | -0.284 | -0.300 |
| | c3/c1 | 0.011 | 0.300 | 0.252 | 0.172 |
| | c4/c1 | 0.011 | 0.300 | -0.038 | -0.149 |
| 0.3 | c1/c1 | 1.000 | 1.000 | 1.000 | 1.000 |
| | c2/c1 | -0.300 | -0.284 | -0.300 | -0.300 |
| | c3/c1 | 0.011 | 0.252 | 0.300 | 0.173 |
| | c4/c1 | 0.011 | 0.252 | 0.300 | 0.000 |
| 0.9 | c1/c1 | 1.000 | 1.000 | 1.000 | 1.000 |
| | c2/c1 | -0.894 | -0.300 | -0.300 | -0.900 |
| | c3/c1 | 0.788 | 0.172 | 0.173 | 0.900 |
| | c4/c1 | 0.788 | 0.172 | 0.173 | 0.000 |

Table 5 Ratio of the relative velocity and the light velocity at the ternary space-times

| $\alpha=W_{a1}/c_1$ | -0.9 | -0.3 | 0.3 | 0.9 |
|---------------------|----------|----------|----------|----------|
| Wad1/c1 | 0.00000 | -0.82192 | -0.94488 | -0.99448 |
| Wad2/c2 | 0.00000 | -0.99927 | 0.99976 | 0.99998 |
| Wad3/c3 | 0.00000 | -0.99961 | -0.99987 | -0.99999 |
| — | | | | |
| Wad1/c1 | 0.82192 | 0.00000 | -0.55046 | -0.94488 |
| Wad2/c2 | 0.99927 | 0.00000 | 0.99844 | 0.99976 |
| Wad3/c3 | 0.99961 | 0.00000 | -0.99916 | -0.99987 |
| — | | | | |
| Wad1/c1 | 0.94488 | 0.55046 | 0.00000 | -0.82192 |
| Wad2/c2 | -0.99976 | -0.99844 | 0.00000 | -0.99927 |
| Wad3/c3 | 0.99987 | 0.99916 | 0.00000 | -0.99961 |
| — | | | | |
| Wad1/c1 | 0.99448 | 0.94488 | 0.82192 | 0.00000 |
| Wad2/c2 | -0.99998 | -0.99976 | 0.99927 | 0.00000 |
| Wad3/c3 | 0.99999 | 0.99987 | 0.99961 | 0.00000 |
| — | | | | |

5.4. Mathematical analysis by theoretical calculation

① Consider the System 4 space-time and organize the formula of 3 above.

$$M_0 = m_{D1} \sqrt{1 - \left(\frac{W_{AD1}}{c_1}\right)^2} = m_{D2} \sqrt{1 - \left(\frac{W_{AD2}}{c_2}\right)^2} = m_{D3} \sqrt{1 - \left(\frac{W_{AD3}}{c_3}\right)^2} = m_{D4} \sqrt{1 - \left(\frac{W_{AD4}}{c_4}\right)^2}$$

$$K = \left(\frac{m_{D1}}{m_{D2}}\right)^2 \frac{(1-\alpha^2)(1-\beta^2)}{(1-\alpha\beta)^2}, \quad L = \left(\frac{m_{D1}}{m_{D3}}\right)^2 \frac{(1-\alpha^2)(1-\beta^2)}{(1-\alpha\beta)^2}, \quad J = \left(\frac{m_{D1}}{m_{D4}}\right)^2 \frac{(1-\alpha^2)(1-\beta^2)}{(1-\alpha\beta)^2}$$

Since the relative velocity $W_{AD1}, W_{AD2}, W_{AD3}, W_{AD4}$ are derived, as a solution

$$\left(\frac{W_{AD2}}{c_2}\right)^2 = 1 - K = \left[\frac{(\beta-\alpha)c_1c_2}{c_2^2 - \alpha\beta c_1^2}\right]^2, \quad \left(\frac{W_{AD3}}{c_3}\right)^2 = 1 - L = \left[\frac{(\beta-\alpha)c_1c_2c_3(c_2^2 - c_1^2)}{c_3^2(\alpha c_1^2 + c_2^2)(\beta c_1^2 + c_2^2) - (1+\alpha)(1+\beta)c_1^2c_2^4}\right]^2$$

$$\left(\frac{W_{AD4}}{c_4}\right)^2 = 1 - J = \left[\frac{(\beta-\alpha)c_1c_2^2c_3^2c_4(c_2^2 - c_1^2)(c_3^2 - c_2^2)}{c_4^2[c_2^2(c_3^2 + c_1c_2) + \alpha c_1(c_1c_3^2 + c_2^3)] \cdot [c_2^2(c_3^2 + c_1c_2) + \beta c_1(c_1c_3^2 + c_2^3)] - c_2^2c_3^4(c_1 + c_2)^2(\alpha c_1 + c_2)(\beta c_1 + c_2)}\right]^2$$

Mode-1 solution ; Expanding $(w_{AD}/c)^2 = [\dots]^2$

$$A(c^2)^2 + B(c^2) + C = 0 \quad c = \delta_2 \sqrt{[-B + \delta_1 \sqrt{B^2 - 4AC}] / 2A}$$

Mode-2 solution ; Taking square root $(w_{AD}/c)^2 = [\dots]^2$

$$A\delta'_1 \sqrt{1-L} c^2 + Bc + C\delta'_1 \sqrt{1-L} = 0 \quad c = \frac{-B + \delta'_2 \sqrt{B^2 - 4AC(1-L)}}{2A\delta'_1 \sqrt{1-L}}$$

② With the Mode -1 solution, determine the sign ± 1 of $(\delta_1, \delta_2), (\delta_3, \delta_4), (\delta_5, \delta_6)$.

Since the System 1 moves at the light velocity in the System 2 space-time, there is a part where the System 1 space-time and the System 2 space-time are in contact. Consider the momentum tensor when an object (photon) exists at the boundary between the System 1 space-time and the System 2 space-time, and apply "the principle of least action" to this photon momentum tensor.

Photon momentum in the System 1 space-time $p_1 = h_1 v_1 / c_1$,

Photon momentum in the System 2 space-time $p_2 = h_2 v_2 / c_2$

" the principle of Photon momentum least action" $\text{Min} [p_1 + p_2]$

$$\begin{aligned} \text{Min} [h_1 v_1 / c_1 + h_2 v_2 / c_2] &= \text{Min} h_1 v_1 / c_1 [1 + h_2 v_2 / h_1 v_1 \cdot c_1 / c_2] \\ &= \text{Min} \frac{h_1 v_1}{c_1} \left[1 + \frac{h_2 v_2}{h_1 v_1} \delta_2 / \sqrt{\frac{1}{2(1-K)} [\alpha^2 + \beta^2 - 2\alpha\beta K + |\alpha - \beta| \delta_1 \sqrt{(\alpha + \beta)^2 - 4\alpha\beta K}] } \right] \end{aligned}$$

$$\Rightarrow \text{for minimum, } \delta_2 = -1$$

Also, $\text{Min} [h_2 v_2 / c_2 + h_3 v_3 / c_3]$

$$\Rightarrow \text{for minimum, } \delta_4 = +1, \quad \text{because of } \delta_2 = -1, \quad c_2 \text{ and } c_3 \text{ are opposite sign.}$$

Also, $\text{Min} [h_3 v_3 / c_3 + h_4 v_4 / c_4]$

$$\Rightarrow \text{for minimum, } \delta_6 = -1, \quad \text{because of } \delta_4 = +1, \quad c_3 \text{ and } c_4 \text{ are opposite sign.}$$

Furthermore, in order to determine $\delta_1, \delta_3, \delta_5$, the condition that the speed of the object does not exceed the light velocity is applied. For the System 2 space-time

$$\left(\frac{w_{D2}}{c_2} \right)^2 = \left(\frac{1}{c_2} \cdot \frac{w_{D1} + c_1}{1 + w_{D1} c_1 / c_2^2} \right)^2 = \frac{2(1-K)(1+\beta)^2(\alpha^2 + \beta^2 - 2\alpha\beta K + |\alpha - \beta| \delta_1 \sqrt{(\alpha + \beta)^2 - 4\alpha\beta K})}{[2(1-K)\beta + \alpha^2 + \beta^2 - 2\alpha\beta K + |\alpha - \beta| \delta_1 \sqrt{(\alpha + \beta)^2 - 4\alpha\beta K}]^2} < 1$$

$$\text{If so } \frac{\partial}{\partial \delta_1} \left(\frac{w_{D2}}{c_2} \right)^2 = 0, \quad \delta_1 = \frac{-\sqrt{(\alpha + \beta)^2 - 4\alpha\beta K}}{|\alpha - \beta|} < 0, \quad \text{therefore } \delta_1 = -1$$

$$\text{Also, for the System 3 space-time } \left(\frac{w_{D3}}{c_3} \right)^2 < 1, \quad \text{if so } \frac{\partial}{\partial \delta_3} \left(\frac{w_{D3}}{c_3} \right)^2 = 0, \quad \text{therefore } \delta_3 = -1$$

$$\text{Also, for the System 4 space-time } \left(\frac{w_{D4}}{c_4} \right)^2 < 1, \quad \text{if so } \frac{\partial}{\partial \delta_5} \left(\frac{w_{D4}}{c_4} \right)^2 = 0$$

$$\begin{aligned} \delta_5 &\sqrt{\frac{\{ 2[(c_2^2(c_3^2 + c_1 c_2) + \alpha c_1(c_1 c_3^2 + c_2^3))][c_2^2(c_3^2 + c_1 c_2) + \beta c_1(c_1 c_3^2 + c_2^3)] c_2^2 c_3^4 (c_1 + c_2)^2 (\alpha c_1 + c_2)(\beta c_1 + c_2)(1 - J) \\ &\quad + [(\beta - \alpha) c_1 c_2^2 c_3^2 (c_2^2 - c_1^2) (c_3^2 - c_2^2)]^2 \}}{-4(1 - J)^2 [(c_2^2(c_3^2 + c_1 c_2) + \alpha c_1(c_1 c_3^2 + c_2^3))]^2 [c_2^2(c_3^2 + c_1 c_2) + \beta c_1(c_1 c_3^2 + c_2^3)]^2 [c_2^2 c_3^4 (c_1 + c_2)^2 (\alpha c_1 + c_2)(\beta c_1 + c_2)]^2}} \\ &= 2(1 - J) [(c_2^2(c_3^2 + c_1 c_2) + \alpha c_1(c_1 c_3^2 + c_2^3))]^2 [c_2^2(c_3^2 + c_1 c_2) + \beta c_1(c_1 c_3^2 + c_2^3)]^2 [(1 + \beta) c_1 c_2^2 / (c_2^2 + \beta c_1^2) \\ &\quad + c_2] c_1 c_3^3 / [\beta c_1 c_3^2 + (1 + \beta) c_2^2] - 2[(c_2^2(c_3^2 + c_1 c_2) + \alpha c_1(c_1 c_3^2 + c_2^3))][c_2^2(c_3^2 + c_1 c_2) \\ &\quad + \beta c_1(c_1 c_3^2 + c_2^3)] c_2^2 c_3^4 (c_1 + c_2)^2 (\alpha c_1 + c_2)(\beta c_1 + c_2)(1 - J) - [(\beta - \alpha) c_1 c_2^2 c_3^2 (c_2^2 - c_1^2) (c_3^2 - c_2^2)]^2 \end{aligned}$$

Since it is $c_2 < 0$, δ_5 fluctuates positively and negatively. That is, in the System 4 space-time, it transits to $\delta_5 = +1$ and $\delta_5 = -1$. As a result, the existence of the System 4 space-time is denied.

Mode -2 solution validating the System 4 space-time c_4

$$\begin{aligned} c_4^2 \delta_5' \sqrt{1 - J} [c_1 c_2^3 (1 + \alpha) + c_3^2 (c_2^2 + \alpha c_1^2)] [c_1 c_2^3 (1 + \beta) + c_3^2 (c_2^2 + \beta c_1^2)] \\ + c_4 (\alpha - \beta) c_1 c_2^2 c_3^2 (c_2^2 - c_1^2) (c_3^2 - c_2^2) - \delta_5' \sqrt{1 - J} c_2^2 c_3^4 (c_1 + c_2)^2 (\alpha c_1 + c_2)(\beta c_1 + c_2) = 0 \end{aligned}$$

In the above c_4 quadratic equation, since coefficients $(\alpha - \beta) c_1 c_2^2 c_3^2 (c_2^2 - c_1^2) (c_3^2 - c_2^2)$ of c_4 terms is greatly affected by the positive and minus signs of $(\alpha - \beta)$, the root changes positively and negatively. As a result, the existence of the System 4 space-time is denied.

Next, consider the rest mass energy of each space-time. For the System 1 space-time to be the least energy in space-time, ε_1 : Baryon. For the System 2, since space-time is $c_2 < 0$, ε_2 : Dark Energy. For the System 3 space-time, the rest is ε_3 : Dark Matter.

6. The cosmic age of dark matter

6.1. The duration time

By the special theory of relativity, when the physical phenomena are observed during time $\Delta t'$ in the rest coordinate, they are observed during time $\Delta t (= \Delta t' / \sqrt{1 - v^2/c^2})$ in the moving coordinate. Therefore, it is possible to express as follow at each of the System 1, 2 and 3 space-times of the ternary space-times.

$$\Delta t_1 = \frac{\Delta t_1'}{\sqrt{1 - w_{AD1}^2/c_1^2}} \quad \Delta t_2 = \frac{\Delta t_2'}{\sqrt{1 - w_{AD2}^2/c_2^2}} \quad \Delta t_3 = \frac{\Delta t_3'}{\sqrt{1 - w_{AD3}^2/c_3^2}}$$

The observation durations of the physical phenomena are common to each of the rest coordinates.

$$\Delta t_1' = \Delta t_2' = \Delta t_3' (= \Delta t_0)$$

$$\Delta t_0 = \Delta t_1 \sqrt{1 - w_{AD1}^2/c_1^2} = \Delta t_2 \sqrt{1 - w_{AD2}^2/c_2^2} = \Delta t_3 \sqrt{1 - w_{AD3}^2/c_3^2}$$

Upper equations Δt_0 are the same that the rest mass equations shown below.

$$M_0 = m_{D1} \sqrt{1 - w_{AD1}^2/c_1^2} = m_{D2} \sqrt{1 - w_{AD2}^2/c_2^2} = m_{D3} \sqrt{1 - w_{AD3}^2/c_3^2}$$

So that, it is $\Delta t_1 < \Delta t_2 < \Delta t_3$ in the moving coordinate, because it is $m_{D1} < m_{D2} < m_{D3}$.

The moving duration time Δt_1 of the physical phenomena is the shortest in the System 1 space-time. It means that the physical phenomena have finished and the next step proceeds in the System 1 space-time, while the physical phenomena are being observed in the System 3 space-time. That is, the evolution speed in the System 1 space-time is the fastest in the three Systems.

Henceforth, the moving duration time of the physical phenomena is shortly called the duration time.

6.2. The net duration time

There is Plank time as the minimum time-unit. The duration time $\Delta t_1, \Delta t_2$ and Δt_3 are divided finely by Plank time and they are considered to be integrated each Plank time.

$$\Delta t_1 = \Delta t_{11} \quad \Delta t_2 = \Delta t_{21} + \Delta t_{22} \quad \Delta t_3 = \Delta t_{31} + \Delta t_{32} + \Delta t_{33}$$

Δt_{11} : the net duration time of baryons in the System 1 space-time

$\Delta t_{21}, \Delta t_{22}$: the net duration times of baryons and dark energy in the System 2 space-time

$\Delta t_{31}, \Delta t_{32}, \Delta t_{33}$: the net duration times of baryons, dark energy and dark matter in the System 3 space-time

In the System 2 space-time, the duration time of baryons and dark energy is Δt_2 because they appear together. Likewise, in the System 3 space-time, the duration time of baryons, dark energy and dark matter is Δt_3 because they appear all together,

The net duration time of baryons is common in the System 1,2 and 3 space-times, $\Delta t_{11} = \Delta t_{21} = \Delta t_{31}$

The net duration time of dark energy is common in the System 2 and 3 space-times, $\Delta t_{22} = \Delta t_{32}$

The net duration time of dark matter in the System 3 space-time is Δt_{33}

Consequently, $\Delta t_1 = \Delta t_{11} \quad \Delta t_2 = \Delta t_{11} + \Delta t_{22} \quad \Delta t_3 = \Delta t_{11} + \Delta t_{22} + \Delta t_{33}$

integrated Plank time

Because their relations equal to that of the mass of motion, it follows

$$\begin{aligned} \Delta t_{11} &= \varepsilon_1 T & \Delta t_{22} &= \varepsilon_2 T & \Delta t_{33} &= \varepsilon_3 T \\ \Delta t_1 &= \varepsilon_1 T & \Delta t_2 &= (\varepsilon_1 + \varepsilon_2) T & \Delta t_3 &= (\varepsilon_1 + \varepsilon_2 + \varepsilon_3) T \end{aligned}$$

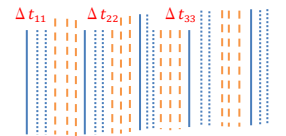

The net change rate of the physical phenomena is in inverse proportion to the net duration time and the net change length is in proportion to the net change rate. So that, in the System 3 space-time.

the net change length of dark matter / the net change length of baryons

$$= \text{the net duration time of baryons } \Delta t_{31} / \text{the net duration time of dark matter } \Delta t_{33} = \varepsilon_1 / \varepsilon_3$$

6.3. The reaction rate of the physical phenomena

Evolution process of dark matter is much more unclear than that of baryons. Here, chemical reaction engineering is introduced. Chemical reaction rate (stochastic process) is in proportion to density (i.e. mass / space volume). So that, the relations between baryons and dark matter in the System 3 space-time are as follow.

| | baryons | dark matter |
|--------------------------|---|---|
| light velocity | c_3 | c_3 |
| mass | ε_1 | ε_3 |
| net duration time | Δt_{31} | Δt_{33} |
| virtual space volume | $(c_3 \Delta t_{31})^3$ | $(c_3 \Delta t_{33})^3$ |
| virtual density | $\varepsilon_1 / (c_3 \Delta t_{31})^3$ | $\varepsilon_3 / (c_3 \Delta t_{33})^3$ |
| ratio of virtual density | 1.0 | $\varepsilon_3 / \varepsilon_1 \cdot (\Delta t_{31} / \Delta t_{33})^3 = (\varepsilon_1 / \varepsilon_3)^2$ |

6.4. The cosmic age of dark matter

The net evolution length (cosmic age) of dark matter is with relation to the net duration time of Plank time and the reaction rate of the physical phenomena.

$$\begin{aligned} & \frac{\text{the net evolution length (cosmic age) of dark matter}}{\text{the net evolution length (cosmic age) of baryons}} \\ &= \frac{\text{the net duration time of baryons}}{\text{the net duration time of dark matter}} \times \frac{\text{the net reaction rate of dark matter}}{\text{the net reaction rate of baryons}} \\ &= (\varepsilon_1 / \varepsilon_3) \cdot (\varepsilon_1 / \varepsilon_3)^2 = \left(\frac{\varepsilon_1}{\varepsilon_3} \right)^3 \end{aligned}$$

When the net evolution length of baryons is 13.8 billion years cosmic age in the System 3 space-time, the cosmic age of dark matter can be about 100 million years $[0.08\text{billion}=13.8 \times (0.049/0.268)^3]$. The cosmic age about 100 million years locates in the dark ages of universe (cosmic age from 0.37 million to about 400 million years) without any lights i.e. electromagnetic waves but with gravitation. (Fig 2)

Evolution process of dark energy is most difficult of three Systems. Nevertheless boldly speaking, the cosmic age of dark energy can be about 0.5 million years $[13.8 \times (\varepsilon_1 / \varepsilon_2)^3]$. But gravity except both electro- magnetic force and photon radiated from dark energy can be felt in the System 3 space-time, because the light velocity c_2 is negative in the System 2 space-time where dark energy occurred.

In the first place, the capture of elementary particles (including photons, gravitons and other elementary particles with the light velocity) between Ba, DE and DM is not suitable because it causes fluctuations in the ε of the Systems 1, 2 and 3. However, gravities which are distortions of the space-time field, exist and act. (they are characteristics of origin space-time.) ε varies with α and β as (Eq.7), (Eq.8).

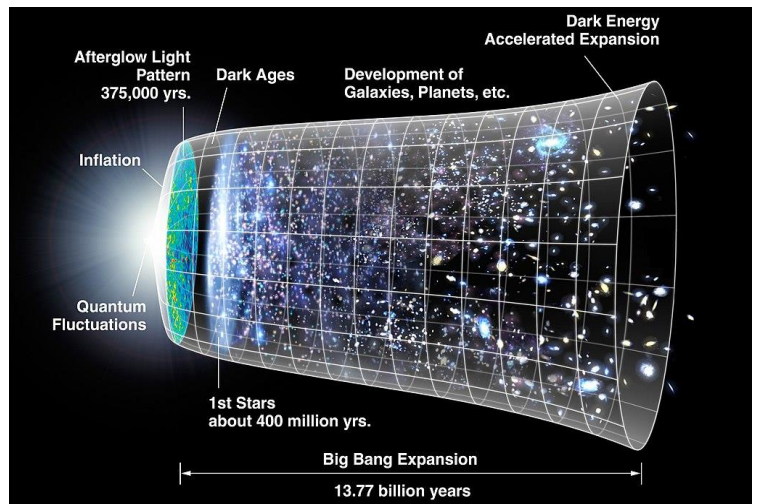

Fig 2 Big Bang Expansion

CMB Timeline300 no WMAP.jpg

Courtesy of NASA

7. Discussion

In summary, it estimates the ternary space-times by using the formulae for both combined velocities and the increasing mass which are completed in the accelerated motion from the special theory of relativity.

Dark matter is a product in the System 3 space-time, and the System 3 is the present “real world” with a positive light velocity (300,000 km/s). So that, dark matter gathers around baryons in the System 3 space-time because of the positive light velocity c_3 . (Fig.3, Fig.4)

Dark energy is a product in the System 2 space-time, and the System 2 is the “illusiv world” with a negative light velocity that is ten times faster ($c_2/c_3 : -1.0 \sim -89$) than that in the real world. The System 2 also has negative pressure since this is a negative light velocity world, i.e., it represents the expansion of the universe itself. So that, dark energy disperses in the System 2 because of the negative light velocity c_2 .

Baryons is a product in the System 1 space-time and the System 1 is the “core world” with a positive light velocity c_1 that is hundred times faster ($c_1/c_3 : 1.1 \sim 890$) than that in the real world. So that, baryons gather each other because of the positive light velocity c_1 .

Dark matter and dark energy are the magics of the ternary space-times and generated from baryons of the core world. It is impossible to directly capture substances proper i.e. elementary particles of dark matter in the System 3 space-time, because this real world is separated from the System 1 where the core world exists due to the space-time light velocity energy gaps. Substances of dark energy in the System 2 space-time are the same as above. So that, baryons never collide with dark matter.

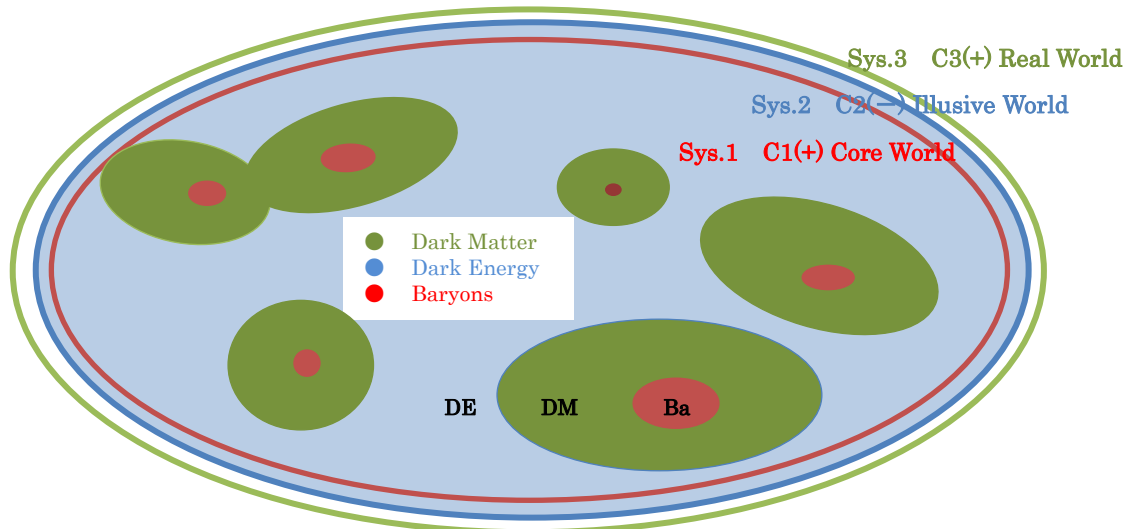

Fig.3 Image of the ternary space-times

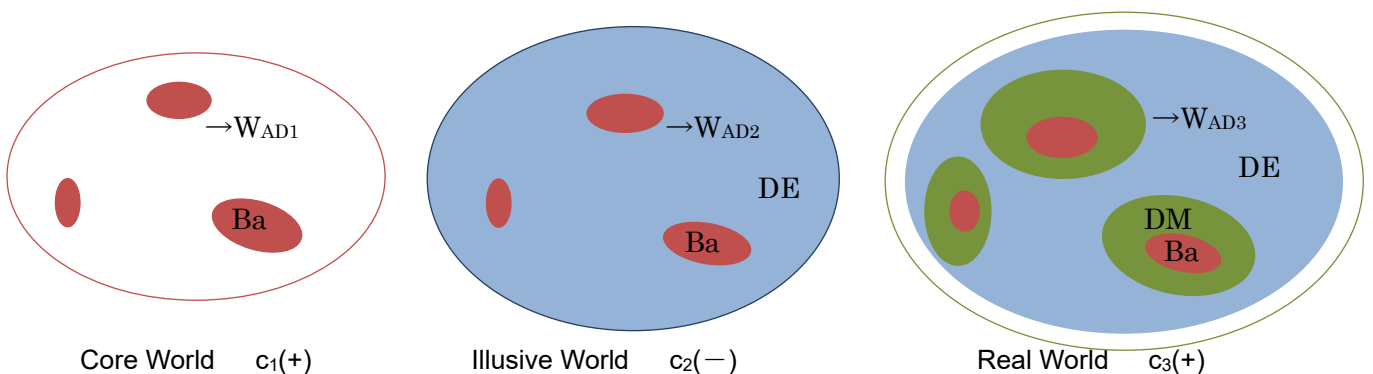

Fig.4-1 the System 1 space-time

Fig.4-2 the System 2 space-time

Fig.4-3 the System 3 space-time

| | galaxy relative speed | | | mass of motion | | | virtual (net) duration time of motion | | |
|-------------|-----------------------|-----------|-----------|-------------------|-------------------|-------------------|---------------------------------------|--------------------------------|--------------------------------|
| | Sys.1 | Sys.2 | Sys.3 | Sys.1 | Sys.2 | Sys.3 | Sys.1 | Sys.2 | Sys.3 |
| baryons | w_{AD1} | w_{AD2} | w_{AD3} | $\varepsilon_1 m$ | $\varepsilon_1 m$ | $\varepsilon_1 m$ | $\Delta t_1 (\varepsilon_1 T)$ | $\Delta t_2 (\varepsilon_1 T)$ | $\Delta t_3 (\varepsilon_1 T)$ |
| dark energy | — | w_{AD2} | w_{AD3} | — | $\varepsilon_2 m$ | $\varepsilon_2 m$ | — | $\Delta t_2 (\varepsilon_2 T)$ | $\Delta t_3 (\varepsilon_2 T)$ |
| dark matter | — | — | w_{AD3} | — | — | $\varepsilon_3 m$ | — | — | $\Delta t_3 (\varepsilon_2 T)$ |

Effect of dark matter and dark energy against baryons in the System 3 space-time

| | dark matter | dark energy |
|-----------------------------|--|--|
| gravity field | • gravity field & gravity force occur. | • gravity field & gravity force with the negative light velocity occur. |
| electromagnetic field | • electromagnetic field occurs but its wave does not, because it is in Dark Ages without free light. | • electromagnetic field occurs but its wave does not, because it is in Dark Ages without free light. |
| elementary particles | • they cannot be captured because of substances in the differential space-times | • they cannot be captured because of substances in the differential space-times |
| cosmic background radiation | • it exists in transition the System 2 to the System 3 space-time. | • it exists in transition the System 1 to the System 2 space-time. |

It is difficult to apply the theory of relativity to the very early universe era when the sudden expansion of the universe occurred. However, it is possible to apply the theory of relativity to the era of after early universe. When the universe transitioned from the System 1 space-time to the System 2 space-time in inflationary epoch of the very early universe, the mass of motion $\varepsilon_2 m$ increased in accordance with the equation $E_2 = m(\varepsilon_1 + \varepsilon_2) c_2^2 \sqrt{1 - (w_{AD2}/c_2)^2}$ as an enlarged copy of inflatons $\varepsilon_1 m$. Inflatons composed of elementary particles in the System 1 space-time collapsed into standard model particles (electron, photon, neutrino, proton, neutron, etc.) with the lapse of time. On the other hand, inflatons i.e. elementary particles which occurred in the System 2 and the System 3 space-times developed on their own over time.

Baryons lapse cosmic age 13.8 billion years from the big bang. The cosmic age of dark energy can be about 5 million years and the cosmic age of dark matter can be about 100 million years, if the processes of evolution in the System 1, 2 and 3 space-times are similar because dark energy and dark matter are enlarged copies of baryons. These cosmic ages of dark energy and dark matter locate in the dark ages (from cosmic age 0.37 million to about 0.4 billion years) of universe without any light by the chronology of the universe.

The movement speeds of baryons and dark energy are equal since the speed w_{AD2} is common to baryons and dark energy in the System 2 space-time. The same can be said to the System 3 space-time. As a result, it can be concluded that dark matter (halo) is located around baryons (galaxy) as shown in Fig.5. Even if baryons assemblies with extensive innocent spaces collide each other like Bullet Galaxy (Fig. 6), baryons proper don't clash but pass through the collision space, meanwhile dark matter and dark energy belonging to baryons also don't clash. Each of some baryons or dark matter assemblies might happen to clash and be left behind incidentally, meanwhile others of baryons or dark matter pass through. Those results separate dark matter from baryons.

The ternary space-times universe was created in the inflationary epoch during the very early universe. Dark energy was made in the earlier inflationary epoch and dark matter was made in the big bang.

There must be two cosmic background radiations which result from transition to the System 2 and to the System 3 space-time, but the cosmic background radiation in the System 2 space-time is not sensitive in the System 3 space-time because of its negative light velocity.

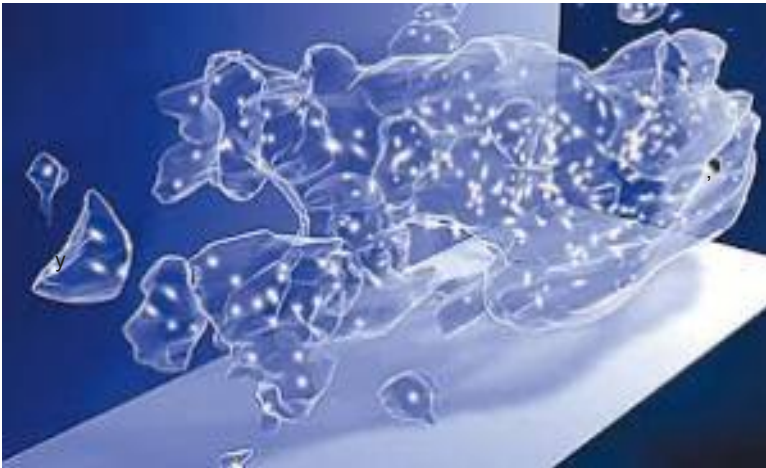

White spots are galaxies and clear jellies are dark matters.

Courtesy of NASA, ESA, R. Massey

Fig.5 Image of dark matter and the galaxy [5]



Two blue areas are dark matters.

Courtesy of NASA, CXC, CfA

Fig.6 Bullet Galaxy

References

- [1] Planck reveals an almost perfect Universe. *European Space Agency*, [https://www.esa.int/Our Activities/Space Science/Planck/Planck reveals an almost perfect Universe](https://www.esa.int/Our_Activities/Space_Science/Planck/Planck_reveals_an_almost_perfect_Universe) (2013); accessed on April 2018.
- [2] Sofue, Y. & Rubin, V C. Rotation curves of spiral galaxies. *Annu. Rev. Astron. Astrophys.* 39, 137 (2001).
- [3] Hubble, E. A relation between distance and radial velocity among extra-galactic nebulae. *Proc. National Academy of Sciences* **15**, 168–173 (1929).
- [4] Battaglia, G. et al. The radial velocity dispersion profile of the galactic halo: Constraining the density profile of the dark halo of the Milky Way. *Mon. Notices Royal Astron. Soc.*, 364, 433 (2005).
- [5] First 3D map of the Universe's Dark Matter scaffolding, [http://www.esa.int/.../First 3D map of the Universe's dark matter...](http://www.esa.int/.../First_3D_map_of_the_Universe's_dark_matter...); accessed on April 2018.

Declarations

Acknowledgements

Funding: This research did not receive any specific grant from funding agencies in the public, commercial, or not-for-profit sectors.

I thank Dr. Yuko Masaki for editing an early draft of this manuscript.

Author Contributions

F. I. developed the theory and wrote the manuscript.

Competing Interests

The author declares no competing interests including financial and non-financial interests.

An additional remark

F.I. presented this paper in 2019 Spring Annual Meeting Proceedings, Astronomical Society of Japan.

Many papers like this were submitted to *NATURE astronomy*, *PHYSICS of the DARK UNIVERSE* and many journals in 2018. But all journals against publication rejected it because this paper article is beyond the scope of the journals. Even *PHYSICS of the DARK UNIVERSE* journal editor said to focus on particle physics models of dark matter and dark energy and their experimental tests.

This paper describes that it is impossible to directly capture the dark matter substances proper in the System 3 space-time, which is against the principle of journals, so that it was rejected. I am looking forward to around 2050 when scientifically correct intelligence and evaluation should be achieved. We have a purpose to live over 100 years old cheerly. Thank you.